

Intesis INBACMID001I100 Gateway

Safety Information



Follow these instructions carefully. Improper work may seriously harm your health and damage the gateway and/or any other equipment connected to it.

- Only technical personnel, following these instructions and the country legislation for installing electric equipment, can install and manipulate this gateway.
- Install this gateway indoors, in a restricted access location, avoiding exposure to direct solar radiation, water, high relative humidity, or dust.
- All wires for communication and power supply must only be connected to networks without routing to the outside plant. All communication ports are considered for indoor use and must only be connected to SELV circuits.
- Mount the gateway, preferably, on a DIN rail inside a grounded metal cabinet following the instructions below.
- In the case of wall mounting, firmly fix the gateway on a non-vibrating surface following the instructions below.
- Disconnect any system from power before handling or connecting it to the gateway.
- Respect the expected polarity of power and communication cables when connecting them to the gateway.
- Take the necessary antistatic precautions before manipulating the gateway to avoid electrostatic discharges.
- Keep the communication cables as far as possible from mains and ground wires. Do not bundle them together.
- Safety instructions in other languages can be found [here](#).

Installation Instructions

1. Disconnect all systems from power.
2. Set the DIP switches according to your requirements.
3. Mount the gateway. DIN rail mounting inside a grounded metal cabinet is recommended.
4. Connect the indoor unit's XYE/D1D2 bus to the gateway's **RC Bus** port.
 - For V4 and V6 models, use the XYE terminals.
 - For V8 models, use the D1D2 terminals.
 - To know more about the compatibility of the gateway with V8 models, refer to the User Manual.
5. Connect the BACnet MS/TP bus to the gateway's **EIA-485** port.
6. Connect the power supply to the gateway's **Power** port.
7. Reconnect all systems to power.

Power Supply Requirements

- Required power supply:
 - **Voltage: 12 VDC/AC**
 - **Current: ≥200 mA**
- Use a SELV-rated NEC Class 2 or Limited Power Source (LPS) power supply.
- Respect the polarity.
- Maximum cable length: 3 m/10 ft

EIA-485 Bus Requirements

- Use a shielded cable.
- For noise protection, use the shield as a drain wire by connecting it to the SG terminal at one end only.
- Maximum distance of 1200 meters (4000 ft).
- Up to 32 devices can be connected.
- A 120 Ω resistor is required at each end of the bus. (See the DIP switches section).

Standalone solution. Using a remote controller is optional

The gateway can operate as a standalone solution or coexist with a remote controller connected to the X1X2 terminals, whether it is configured as a header (main) or a follower (sub).

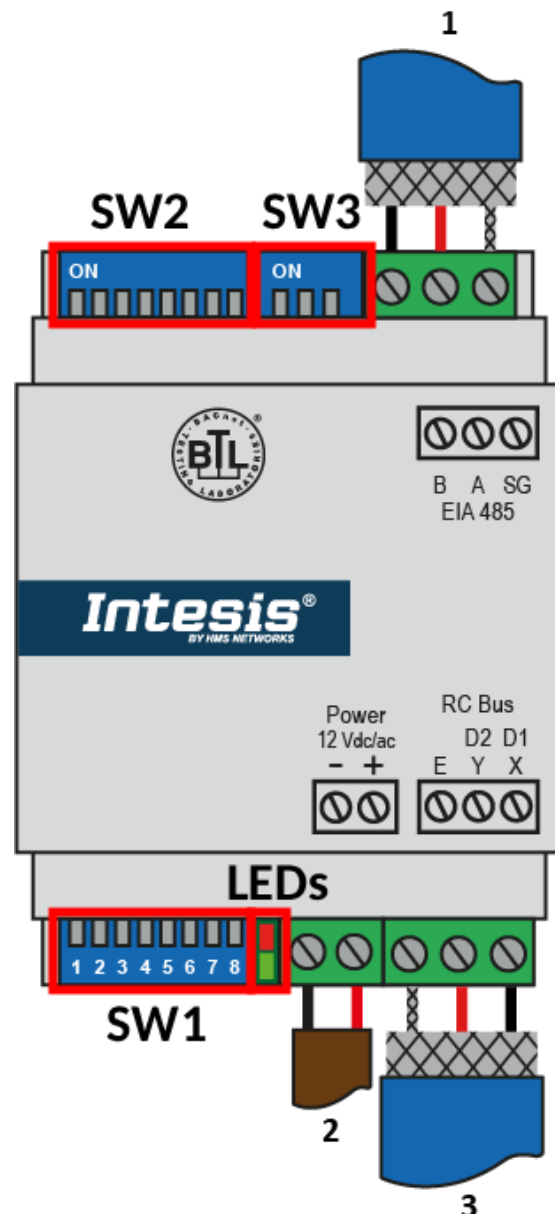

1. BACnet MS/TP EIA-485 bus
2. Power supply
3. Midea E X Y / D1 D2 bus

Configuration Through DIP Switches

Important: Set the DIP switches before powering the gateway. The settings will be applied during the gateway's startup.

SW1 – Gateway configuration and BACnet MS/TP baudrate

Position						Description
1	2	5	6	7	8	
OFF	OFF	X	X	X	X	Midea V4/V6 system autodetection (default)*
ON	OFF	X	X	X	X	Midea system: V4*
ON	ON	X	X	X	X	Midea system: V6*
X	X	OFF	X	X	X	Low power mode
X	X	ON	X	X	X	High performance mode (default)
X	X	X	OFF	OFF	OFF	Autobaudrate (default)
X	X	X	ON	OFF	OFF	9600 bps
X	X	X	OFF	ON	OFF	19200 bps
X	X	X	ON	ON	OFF	38400 bps
X	X	X	OFF	OFF	ON	57600 bps
X	X	X	ON	OFF	ON	76800 bps
X	X	X	OFF	ON	OFF	115200 bps
X	X	X	ON	ON	ON	Autobaudrate

NOTE:

Positions not listed are not used.

NOTE:

Positions 1 and 2 from SW1 are used to set the Midea VRF model, whether it is V4 or V6.

The gateway is also compatible with Midea VRF V8 models through the D1D2 terminals. However, in this case, the setting of positions 1 and 2 has no effect.

SW2 - BACnet MS/TP MAC address

Position							MAC address
1	2	3	4	5	6	7	
OFF	OFF	OFF	OFF	OFF	OFF	OFF	0
ON	OFF	OFF	OFF	OFF	OFF	OFF	1
OFF	ON	OFF	OFF	OFF	OFF	OFF	2
ON	ON	OFF	OFF	OFF	OFF	OFF	3
...							...
ON	OFF	ON	ON	ON	ON	ON	125
OFF	ON	ON	ON	ON	ON	ON	126
ON	ON	ON	ON	ON	ON	ON	127

Setting the MAC address

To determine the position of each switch for addressing, convert the decimal value of the address to binary. A value of 0 indicates the switch is set to OFF, while a value of 1 indicates it is set to ON. Keep in mind that P1 represents the least significant bit (LSB).

Example to set the address 34:

1. Convert the value to binary: 100010.
2. Read the binary value from right (MSB) to left (LSB).
3. Set each switch accordingly: P1 = OFF, P2 = ON, P3 = OFF, P4 = OFF, P5 = OFF, P6 = ON

Automatic and manual addressing

The gateway implements a device-type object, whose default name and instance are INBACMID001I100 and 246000, respectively. This object identifies the gateway in the BACnet system, either automatically or manually:

- **Automatic addressing (default):** This mode uses a base address of 246000 + the MAC address number set with the DIP switch SW2.
- **Manual addressing:** The gateway switches to this mode when the Object_Identifier property of this object is overwritten from the BACnet side. If so, the DIP switch SW2 configuration will not be considered for the Device instance calculation.

To know more, refer to the User Manual.

SW2 – Temperature units

Position 8	Description
OFF	Temperature in degrees Celsius (°C) (default)
ON	Temperature in degrees Fahrenheit (°F)

SW3 – Polarization and termination

Position			Description
1	2	3	
OFF	X	X	120 Ω termination resistor disabled (default)
ON	X	X	120 Ω termination resistor enabled
X	OFF	OFF	Bus polarization disabled (default)
X	ON	ON	Bus polarization enabled

LED Indicators

LED	Status	Description
Green (L1)	Off	BACnet link not performed
	Steady on	BACnet link established
	Blinking	Activity on the BACnet bus
Red (L2)	Steady on	Gateway – IU communication error
	Blinking	Indoor unit error
	Flashing	Communication OK

Disposal and Recycling



This marking on the product, accessories, packaging, or literature (manual) indicates that the product contains electronic parts and they must be properly disposed of by following the instructions at:

<https://intesis.com/weee-regulation>

For further information on the gateway's installation and configuration, refer to the [User Manual](#).